



PAM-112 Series - Actuator — IOM Manual

08/12/22

For Bray Commercial SSM-250-xxx and SSM-3-xxx Valves Only

Fitting Instructions

Pollution degree II, over voltage category II, as per EN 60730.
 Temperature of the ball pressure test: 257° F (125° C)
 Device can be fitted independently as an attachment. Thermally protected motor.



Fitting Instructions for technicians/fitters

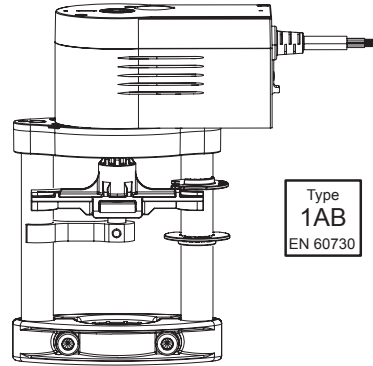

Type
 1AB
 EN 60730



DANGER
 Do not touch hot surfaces - **Danger of burns due to hot surfaces**



DANGER
 Do not reach into dangerous areas - **Moving parts can cause serious injury**

DANGER
 Installation and maintenance may only be carried out by specialists
Risk of injury to inexperienced persons and children

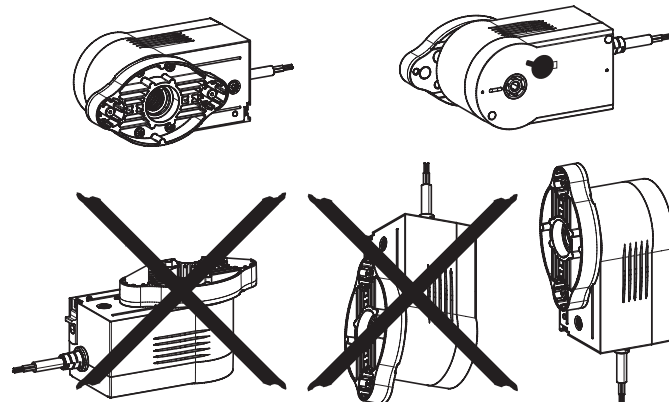
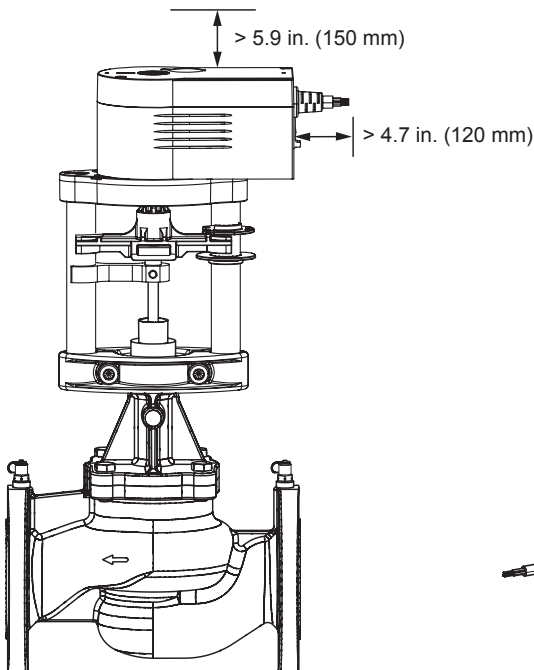
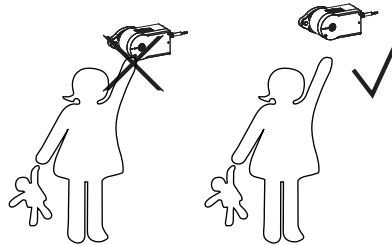

Mounting in a non-specified position can allow water ingress.



Description of Operation

Depending on the type of connection (see wiring diagram), the device can be used as a continuous 0...10 V actuator, a 2-point (OPEN/CLOSE) or 3-point actuator (OPEN/STOP/CLOSE) with an intermediate position. Two running times are available for selection. Switch S3 can be used to select the linear or equal-percentage characteristic. The manual adjustment is performed in the load-free state by releasing the gear unit (slide switch beside the connection cable) and simultaneously turning it with the hex key on the top part of the actuator. 20 mm stroke is achieved with four turns.

Connection as 2-point valve actuator

The 2-point actuation is performed via two cables and it controls the valve actuator to both end positions. The actuator is connected to the voltage via the blue cable [MM] and the brown cable [01]. The actuator spindle extends when the voltage is connected to the black cable [02]. When the voltage on the black cable is switched off, the actuator moves to the opposite end position. In the end positions (limit stop in valve or maximum stroke reached) or in the case of an overload, the electronic motor cut-off is activated (no limit switches). The unused red and grey cables must not be connected or come into contact with other cables. Bray recommends that you insulate these.

Connection as 3-point valve actuator

The 3-point actuation is performed via three cables and controls the valve actuator to any selected position. The actuator is connected to the voltage via the blue cable [MM] and the brown cable [01] or via the black cable [02]. The actuator spindle retracts when the voltage is connected to the brown cable. When the voltage on the brown cable is switched off, the actuator spindle remains in the current position. The actuator spindle extends when the voltage is connected to the black cable. When the voltage on the black cable is switched off, the actuator spindle remains in the current position. The direction of operation is changed by swapping the brown and black cables. In the end positions (limit stop in valve or maximum stroke reached) or in the case of an overload, the electronic motor cut-off is activated (no limit switches). The unused red and grey cables must not be connected or come into contact with other cables. Bray recommends that you insulate these.

Connection as continuous 0...10 V valve actuator

The built-in positioner controls the actuator depending on controller's output signal y . Direction of operation 1 (main power supply on brown cable [01]): When the positioning signal is increasing, the actuator spindle extends. Direction of operation 2 (main power supply on black cable [02]): When the positioning signal is increasing, the actuator spindle retracts. The starting point and control span are fixed. After a manual adjustment or a power failure of more than at least five minutes, the actuator automatically readjusts itself. After the power supply is connected, the stepping motor moves to the lower limit stop, sets up the connection with the valve spindle, moves to the upper limit stop and thus defines the closing position. After this, every stroke between 0 and 20 mm can be achieved, depending on the control voltage. Thanks to the electronics, no steps can be lost, and the actuator does not require periodic re-adjustment. It is possible to operate multiple actuators of the same type in parallel. The feedback signal $y_0 = 0...10$ V corresponds to the effective stroke. When control signal 0...10 V is interrupted and direction of operation 1 (brown cable [01]) is connected, the actuator spindle is retracted. When control signal 0...10 V is interrupted and direction of operation 2 (black cable [02]) is connected, the actuator spindle is extended. The coding switch can be used to select the characteristic of the valve. Characteristics can only be generated when the actuator is used as a continuous actuator. The running times can be selected with additional switches. These can be used for 2-point, 3-point or continuous function.

Additional technical data

The upper section of the housing with the cover, indicator knob and cover knob contains the stepping motor and the actuator electronics. The lower section of the housing contains the maintenance-free gear unit.



Dimensions

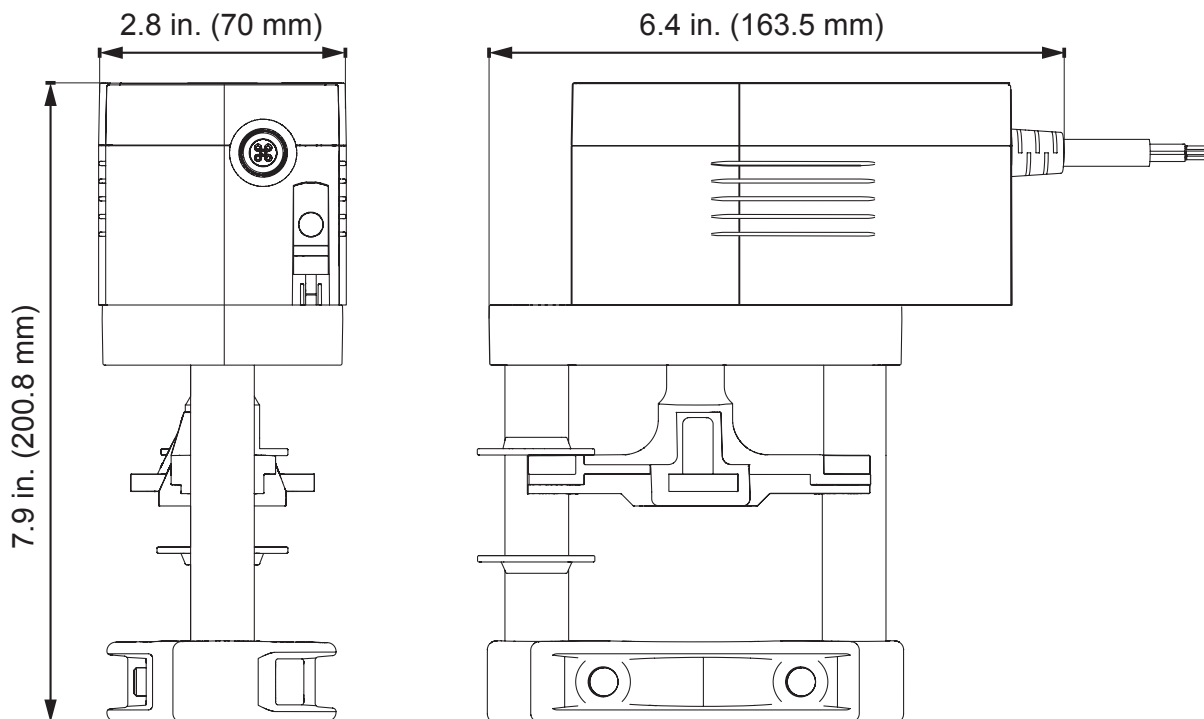

Mounting - Safety and Conditions

1



⚠ DANGER

Danger of electrocution through damaged cables after thermal overload

- ▶ Secure the electricity cables so that they do not come into contact with hot or cold parts.
- ▶ Disconnect the power supply from any defective appliances.



≥9xD

Pay attention to the bend radius of the connection cable

Tools Needed



7/32" or 1/4" (6mm)
Allen Wrench

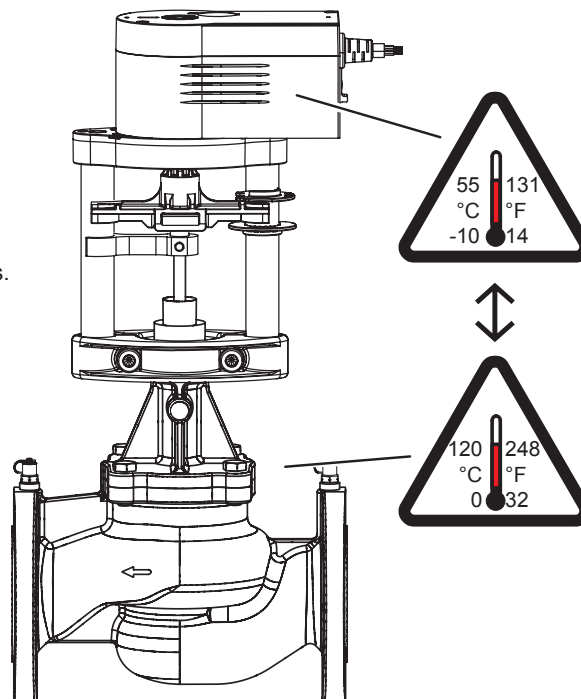

Installation

2

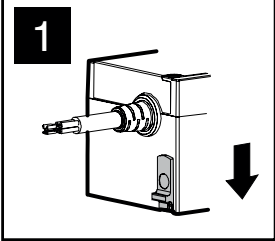
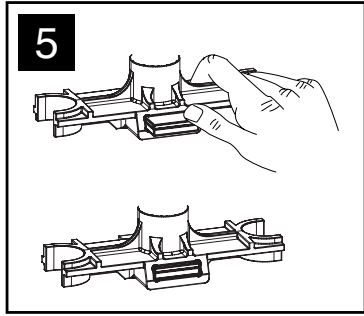

7

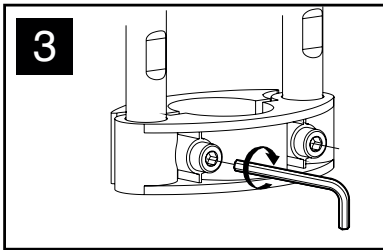
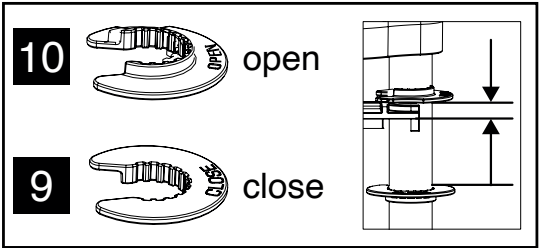
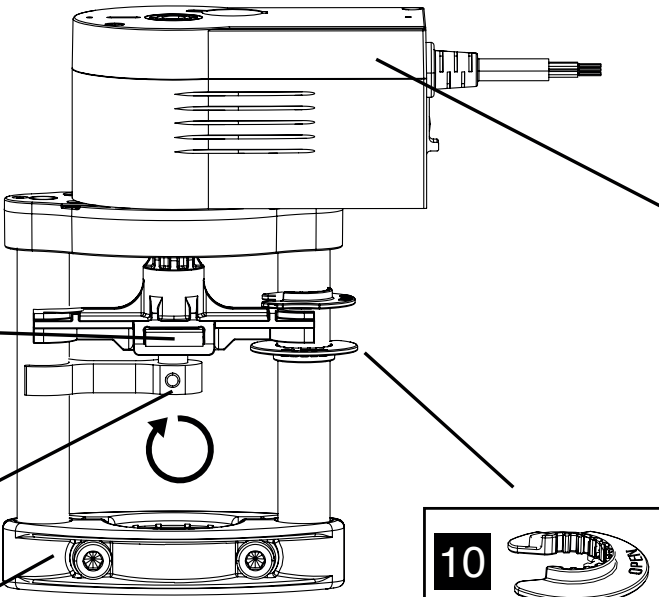

2

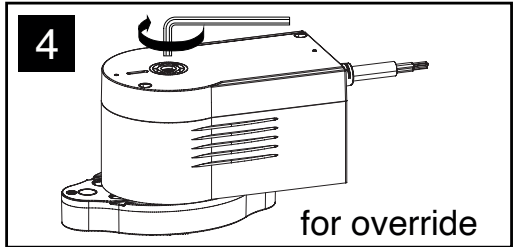

⌚ ↻

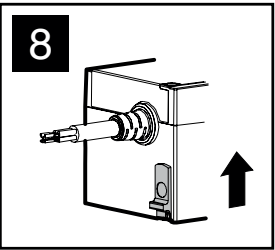
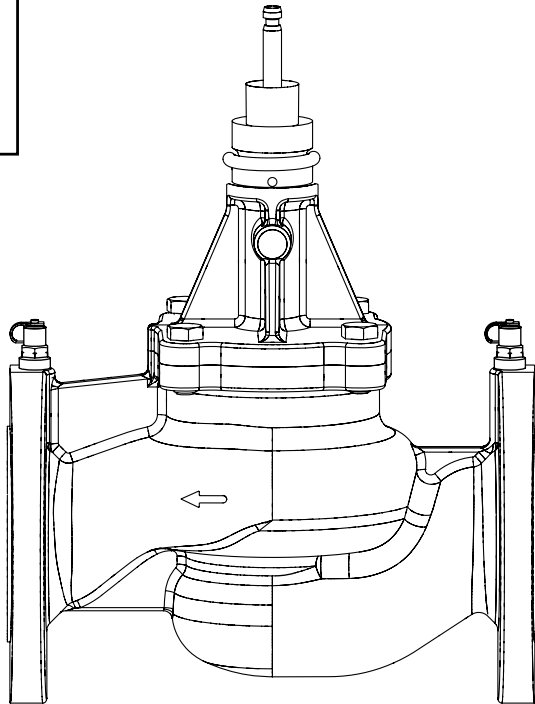
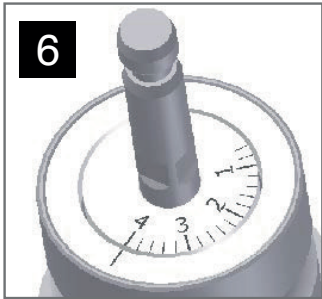



3 Wiring: (Cable)

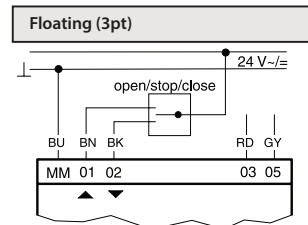
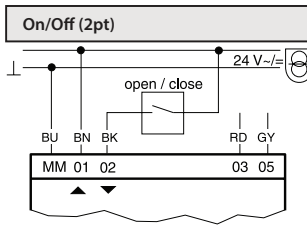
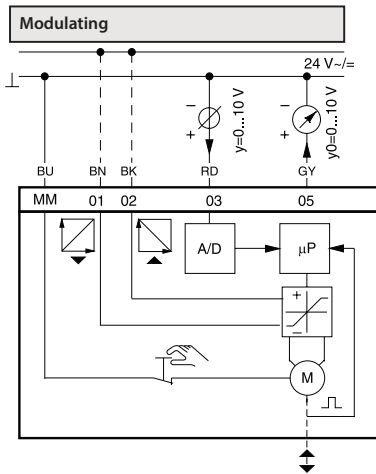

NOTE: For additional operating information see page PA-2.
 The performance specifications are nominal and conform to acceptable industry standards.
 For application at conditions beyond these specifications, consult the nearest Bray office.
 Bray controls shall not be liable for damages resulting from misapplication or misuse of its products.

BU	BN	BK	RD	GY
blue	brown	black	red	grey

4 DIP Switches - Step 1
 (Open the flap on top of the actuator to access the DIP Switches)

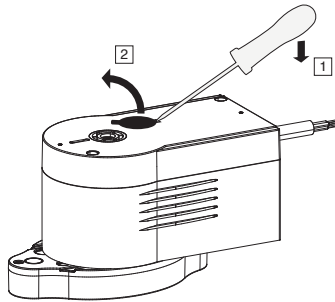

DIP Switches - Step 2
 (Set the DIP Switches)

Running Time Per mm	Switch Coding	Running Time for 8 mm of Stroke	Running Time for 20 mm of Stroke
7,5 s		60 s ± 2	150 s ± 5
15 s		120 s ± 4	300 s ± 10

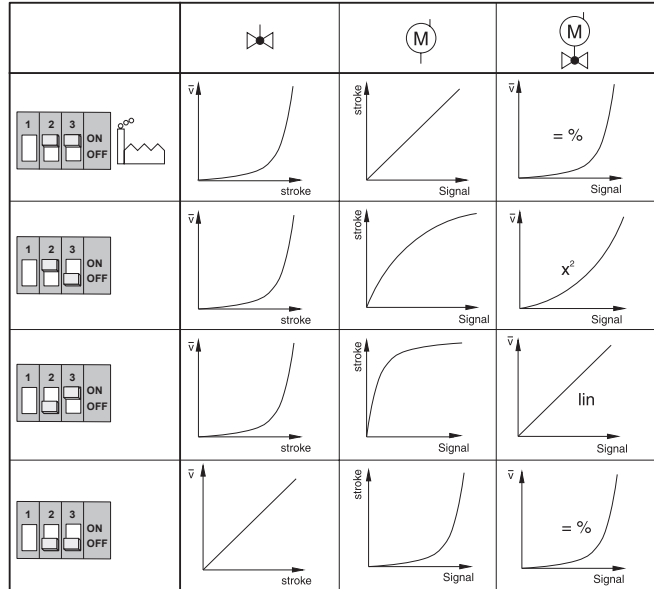

DIP Switches - Step 3
 (Close the flap on top of the actuator to secure the DIP Switches)

